

Welded-On Outlets for Ductile Iron Pipe

Welded-on outlets provide the convenience of a fitting without the added cost and installation expense. A welded outlet can often be fabricated and delivered to a jobsite quicker than a non-standard fitting. This is especially true with larger diameter fitting sizes that are not stock items. Typical applications for welded outlets include valve and hydrant connections, blow-off assemblies and drains. Outlets are available on 24" and larger pipe sizes and can be furnished as either radial side outlets or tangential outlets installed at the top or bottom of the pipe.

Design Guidelines

All components of the welded outlet pipe shall be fabricated from Ductile Iron Pipe manufactured in accordance with **ANSI/AWWA C151/A21.51 "Ductile Iron Pipe, Centrifugally Cast, For Water"**. The welding procedure shall be approved by the pipe manufacturer and shall be strictly adhered to. The welding procedures and all personnel welding the ductile iron components shall be certified in accordance with **ANSI/AWWA D11.2-89 (R2006) "Guide for Welding Iron Castings"**

Welded Outlets can be furnished in the following configurations:

Mechanical Joint Bell

Plain End

Snap-Lok™ Bell or Spigot

Bolt-Lok™ Spigot

Outlets are available in sizes and configurations shown in Tables 1 and 2.

Flanged connections may be supplied for limited applications. Flanged connections are only allowed in vertical positions that are placed inside vaults. Flexible connections shall be provided if horizontal connections are made. Direct burial of flanged connections shall not be allowed.

Restraining devices that prevent the flexibility of mechanical joints shall not be allowed.

All outlet and parent piping shall have a minimum wall thickness equal to Special Thickness Class 53.

Welded outlets shall have a Safety Factor of 2.0 based on a working pressure rating of 250 psi.

Branch connections shall provide joint flexibility adjacent to the welded outlet. A minimum of one flexible joint shall be provided at the connection to the welded outlet and an additional flexible joint shall be provided within the first three feet of branch piping connected to the welded outlet.

Differential settlement between the branch piping and the parent pipe shall be minimized. Type 5 trench bedding shall be used for both the parent pipe and the branch piping. (See Fig. 1)

If branch piping contains restrained joints such as Griffin Snap-Lok™, all excess slack shall be removed during installation. This minimizes the opportunity for subsequent pipe movement to apply excessive bending stresses on the welded outlet. Snap-Lok™ joints on the adjacent parent pipe shall also be fully engaged.

Outlet placement shall maintain 18" clear spacing from the spigot end of the pipe and 24" from the bell end of the pipe. Multi-outlet configurations must maintain 24" of clear spacing between outlets. For cross configurations, the outlet size is limited to 35% of the parent pipe diameter. (See Table 1 and Table 2)

Welded Outlets shall not be used for applications subject to frequent surge pressures or persistent vibration.

Griffin Pipe Products Co. shall review and approve all outlet designs and applications to insure compliance with stated design guidelines prior to manufacture.

Handling and Installation

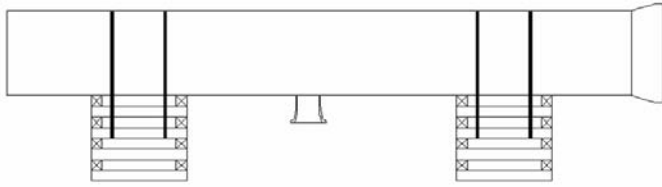

Welded Outlet pipe is shipped on specially designed skids to prevent the pipe from rolling and damaging the outlet. The pipe shall remain on the skids until it is ready to be put into the ground.

The outlet shall not be used to turn or force the parent pipe into position. Leverage forces shall not be applied to the outlet with construction tools or motorized construction equipment such as backhoes. The outlet shall not be used to lift or position the pipe or pipe assembly. Pipe with welded outlets shall not be dropped, bumped, placed in contact with other pipe or the ground during storage. Griffin Pipe Products, Co. shall not be liable for damage to outlets caused by these or other unapproved construction methods.

Figure 1 Recommended Installation Guidelines

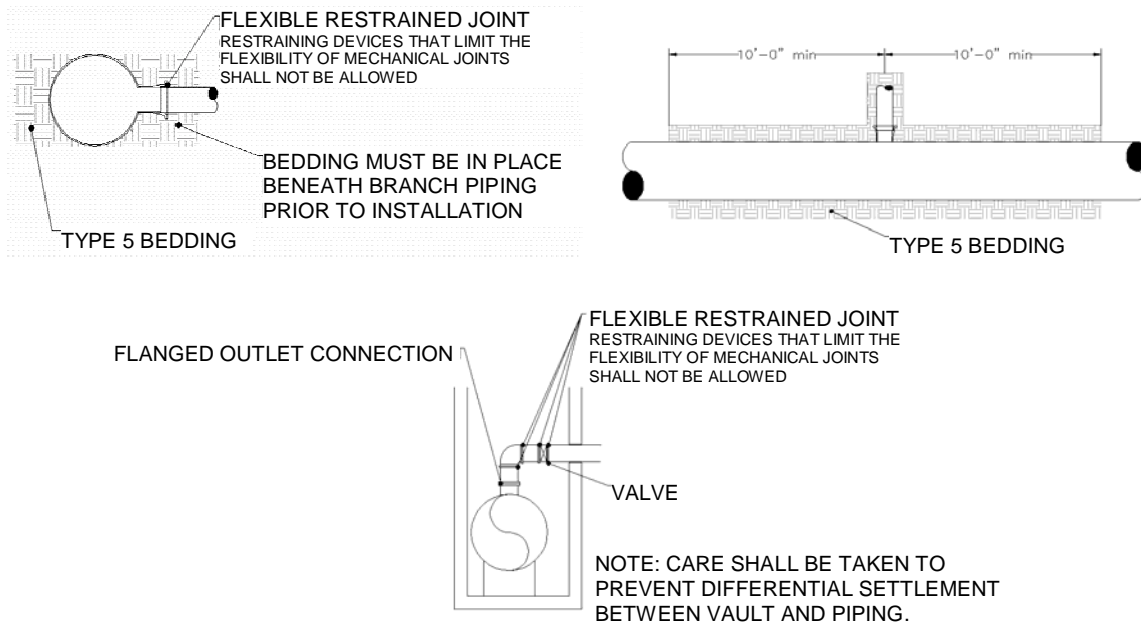

Proper installation requires that pipe connecting to the welded outlets be properly supported prior to connection to the welded outlets. Backfill must be brought to grade to properly support branch piping prior to any connection being made to the welded outlet. Connecting joints must allow for subsequent pipe movement. Rigid joints shall not be connected directly to the welded outlets. If rigid joints are installed near the outlet, at least one flexible joint must be installed between the outlet and the rigid joint. The only exceptions are assemblies that connect laterally from the top of the pipe (such as air-release connections) and are not directly buried. Griffin Pipe Products, Co. shall not be liable for damage to outlets caused by improper installation or design of connecting piping.

RADIAL OUTLETS

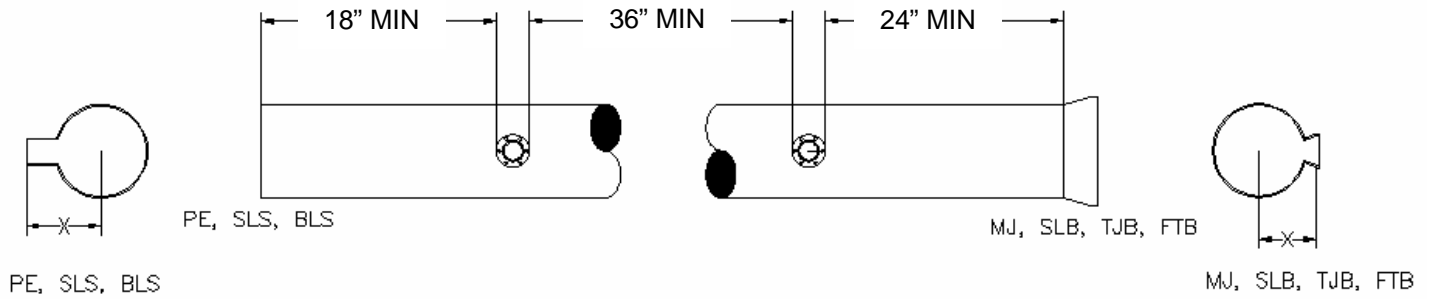

TABLE 1		
PARENT PIPE DIAMETER, IN	AVAILABLE OUTLET DIAMETERS, IN	X, DIMENSION, IN.
24	4 - 16	19
30	4 - 20	23
36	4 - 24	26
42	4 - 30	30
48	4 - 30	34

PE = PLAIN END, SLS = SNAP-LOK™ SPIGOT, BLS = BOLT-LOK™ SPIGOT
 MJ = MECHANICAL JOINT, SLB = SNAP-LOK™ BELL, TJB = TYTON JOINT® BELL, FTB = FASTITE® BELL

ALL DIMENSIONS ARE IN INCHES
 "X" DIMENSION ON PE, SLS, BLS IS FROM THE CENTER OF PIPE TO FACE OF SPIGOT END
 "X" DIMENSION ON MJ, SLB, TJB, FTB IS FROM THE CENTER OF PIPE TO THE THROAT OF THE JOINT
 PARENT PIPE AND OUTLET PIPE SHALL BE MINIMUM THICKNESS CLASS 53
 PRESSURE RATING OF THE WELDED OUTLET PIPE IS LIMITED TO THE LOWEST RATED JOINT IN THE ASSEMBLY
 FLANGED OUTLETS SHALL HAVE THE SAME DIMENSIONS AS PLAIN END CONFIGURATIONS
 FLANGED OUTLETS ARE ONLY ALLOWED IN VERTICAL POSITIONS PLACED INSIDE VAULTS

TANGENTIAL OUTLETS

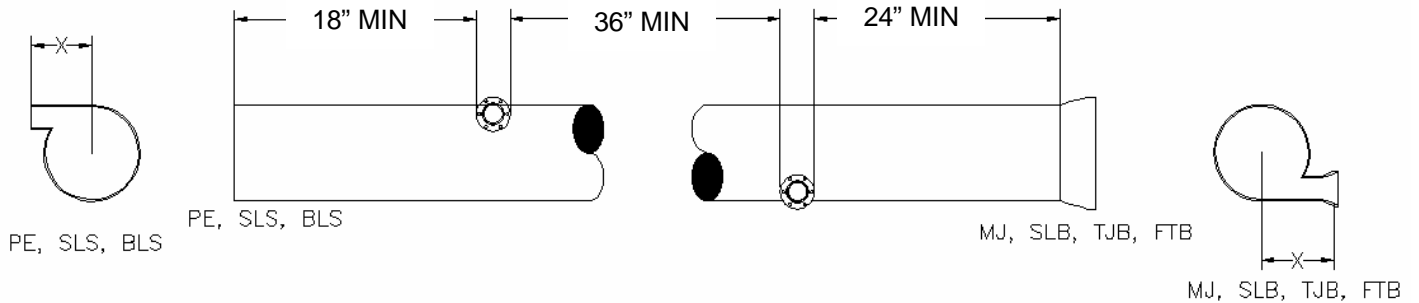

TABLE 2		
PARENT PIPE DIAMETER, IN	AVAILABLE OUTLET DIAMETERS, IN	X, DIMENSION, IN.
24	4 - 16	20
30	4 - 20	24
36	4 - 24	27
42	4 - 30	30
48	4 - 30	34

PE = PLAIN END, SLS = SNAP-LOK™ SPIGOT, BLS = BOLT-LOK™ SPIGOT
 MJ = MECHANICAL JOINT, SLB = SNAP-LOK™ BELL, TJB = TYTON JOINT® BELL, FTB = FASTITE® BELL

ALL DIMENSIONS ARE IN INCHES
 "X" DIMENSION ON PE, SLS, BLS IS FROM THE CENTER OF PIPE TO FACE OF SPIGOT END
 "X" DIMENSION ON MJ, SLB, TJB, FTB IS FROM THE CENTER OF PIPE TO THE THROAT OF THE JOINT
 PARENT PIPE AND OUTLET PIPE SHALL BE MINIMUM THICKNESS CLASS 53
 PRESSURE RATING OF THE WELDED OUTLET PIPE IS LIMITED TO THE LOWEST RATED JOINT IN THE ASSEMBLY
 FLANGED OUTLETS SHALL HAVE THE SAME DIMENSIONS AS PLAIN END CONFIGURATIONS
 FLANGED OUTLETS ARE ONLY ALLOWED IN VERTICAL POSITIONS PLACED INSIDE VAULTS